

PK:

Kunde/*Customer:*

Datum: 45/15

Seite: 1 von 2

Ausführung: Core design:

Ringbandkern *Toroidal core:*

Kern für stromkomp. Drossel
Core for common mode choke

Maßbild: Drawing:

ohne Maßstab / *without scale*
Maße in mm / *Dimensions in mm*

Nennmaße: / Nominal Dimensions:

100 x 80 x 25 mm

Legierung: / Core Material:

VITROPERM 500 F

Fixierung: / Type of Finish:

Fix 022

(Kunststofftrog: Rynite® /
Silikonkautschuk / *Plastic box:*
Rynite® / *silicon rubber*)

Bezugswerte: / Rated

Dimensions:

$$A_{Fe} = 1,9 \text{ cm}^2$$

$$l_{Fe} = 28,3 \text{ cm}$$

$$m_{Fe} = 395 \text{ g}$$

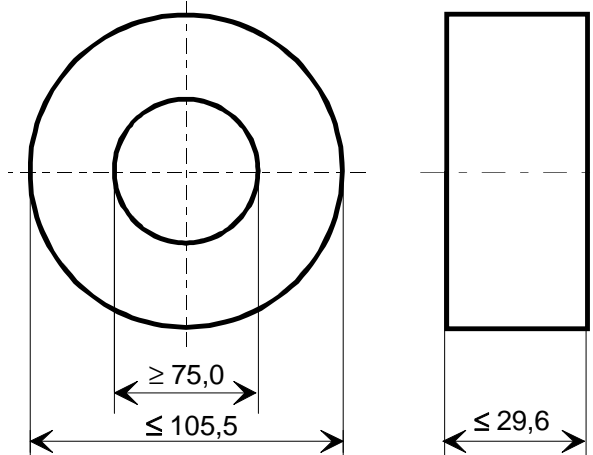

Rev.

Endprüfung: / Final Inspection: (100% Prüfung, AQL...: IEC 410 / DIN ISO 2859)

1. Magnetische Prüfung (AQL 0,65) / Magnetical test (AQL 0,65)

Prüfung des A_L -Wertes im Reihenersatzschaltbild gemäß A60092-Y3022-K009 /

Test of A_L -value in series mode according to A60092-Y3022-K009

Induktivitätsprüfung ohne Gleichstromvormagnetisierung / *Inductance test without DC-magnetisation*

1.1 Einstellwerte / *Setting values:* $I_{eff} \times N = 60 \text{ mA}$
 $f = 10 \text{ kHz}$

Prüfwert / *Specified value:* $10,9 \mu\text{H} \leq A_L \leq 21,1 \mu\text{H}$ (entspr. / *corr.* $12900 \leq \mu_3' \leq 25000$)

1.2 Einstellwerte / *Setting values:* $I_{eff} \times N = 60 \text{ mA}$
 $f = 100 \text{ kHz}$

Prüfwert / *Specified value:* $9,8 \mu\text{H} \leq A_L \leq 20,0 \mu\text{H}$ (entspr. / *corr.* $11600 \leq \mu_3' \leq 23700$)

Herausgeber	Bearbeiter	KB-PM			Datum	freigegeben
KB-E IN	Kleespies	Klinger			10.11.2015	Petzold



Spezifikation für weichmagnetische Kerne
Specification for Soft Magnetic Cores

S-No.:
T60006-L2100-
V081-01-

PK:

Kunde/*Customer:*

Datum: 45/15

Seite: 2 von 2

Hinweise / *Remarks:*

Rev.

1. Due to the very special physical properties of Rynite ® FR530 with respect to temperature and humidity careful attention has to be paid to the following issue:

As a thermoplastic polyester resin, Rynite ® FR530 will hydrolyze in hot water or at elevated temperature together with excessive humidity (e.g. 85 °C / 85 % r.h.) that impacts physical properties of the material. The rate of the hydrolysis depends on exposure conditions; primarily time and temperature. It is recommended not to use Rynite ® FR530 in an environment with continuous exposure to water at temperatures above 50°C. For details see 'DuPont Rynite ® PET Design Guide - Module IV' page 38 'Chemical Resistance' (copy of Table 16 on page 3).

Table 16
Hydrolysis Resistance of Rynite® 530 at
100% RH; Times to Reach One-Half of
Initial Property Value

Tensile Strength	
Temperature	Time (Weeks)
85°C (185°F)	4
70°C (160°F)	22
55°C (130°F)	100
40°C (105°F)	>104

Unnotched Impact	
Temperature	Time (Weeks)
85°C (185°F)	1
70°C (160°F)	6
55°C (130°F)	38
40°C (105°F)	60

As an effect of hydrolytically degradation mechanical strength will degrade, and if there is mechanical stress on the material, like a tense winding, there is a risk that the material will break.

By using 'magnetic cores with core boxes of Rynite ® FR530' this effect has to be taken into account by the user and carefully checked in the final application.

VAC may not take any responsibility for any malfunction due to incorrect handling or use of magnetic cores with core boxes of Rynite ® FR530.

2. Materialnummer / *Part no.:* 97000460